

Pythagoras Theorem Revision Exercise

1) Phil is making a wooden bed frame.

The frame is rectangular and measures 195cm by 95cm.

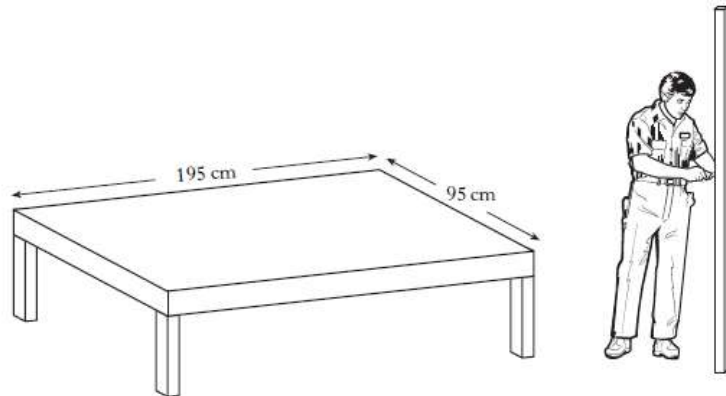

To make the frame rigid, Phil is going to add a piece of wood along one of the diagonals.

He has a piece of wood 2.2m long.

Is this piece of wood long enough to fit along the diagonal?

2) Stephen is playing snooker.

The diagram below shows the position of three balls on the table.

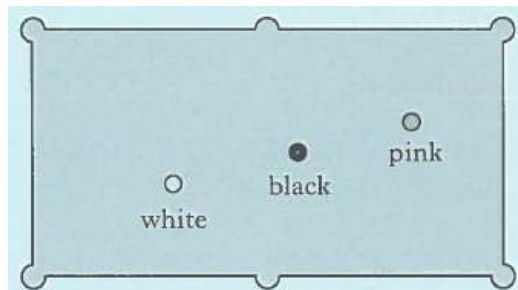

Stephen plays the white ball, W.

It bounces off the side of the table at X and hits the pink ball, P.

- Distance WX is 1.1 metres
- Distance XP is 0.7 metres
- Angle WXP is 90°

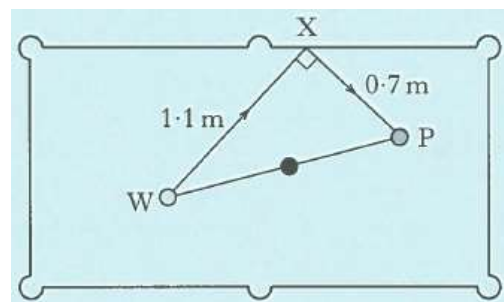

Calculate distance WP.

- 3) Gold chains are displayed diagonally on a square board of side 20 inches.
The longest chain stretches from corner to corner.
Calculate the length of the longest chain.

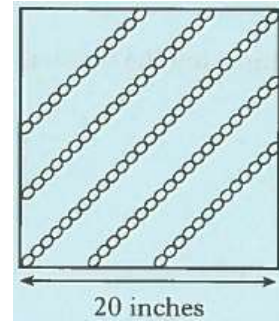

- 4) a) Write down the coordinates of the points A and B marked on this diagram.

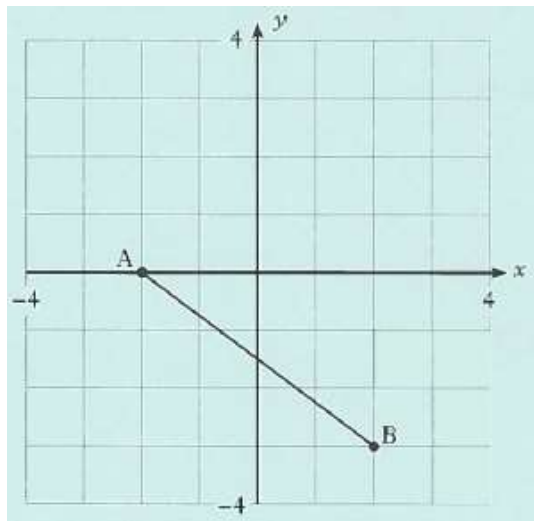

- b) Calculate the length of the line joining A to B.

- 5) PQRS is a rhombus.
The diagonals PR and QS are 15 cm and 8 cm long as shown.
Calculate the length of side PQ.

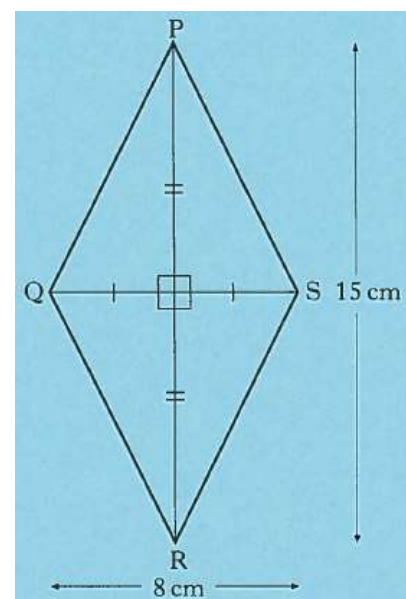

- 6) The diagram shows the front view of a garage.

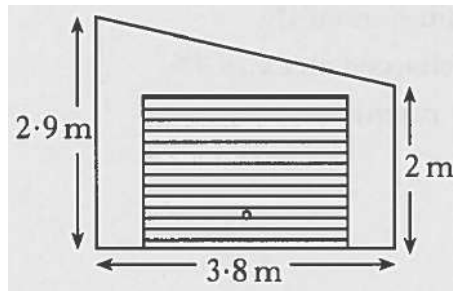

Calculate the length of the sloping edge of the roof.

- 7) A bypass is being built to reduce the traffic passing through Steevley as shown in the diagram.

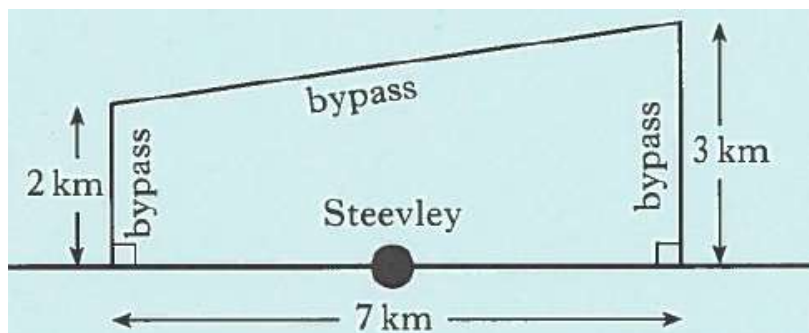

Calculate the total length of the bypass.

- 8) The diagram below shows the position of a ceiling fan in a conservatory.

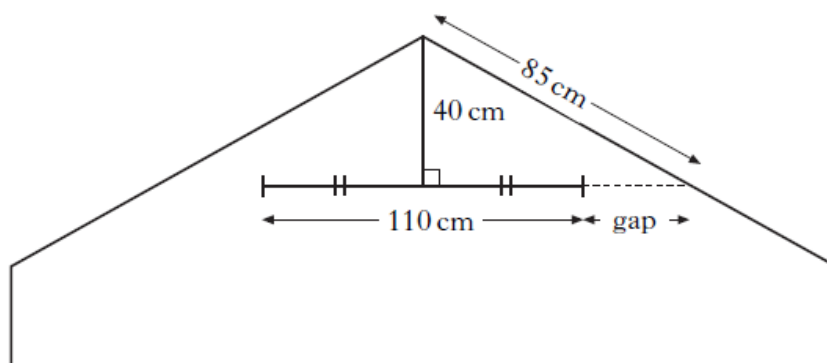

- The fan is 40cm below the top of the conservatory.
- The sloping roof measures 85cm to the level of the fan.
- The fan measures 110cm across.

Calculate the size of the gap between the edge of the fan and the sloping roof.

9) A wooden gate is 85cm high and 200cm wide

The gate is strengthened by two bars which meet half-way across the gate as shown.

The ends of each bar measure 15cm.

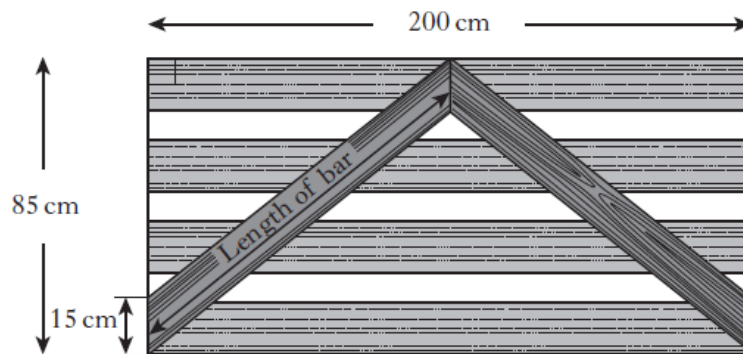

Calculate the length of one of the bars.

10) The screen size of a laptop computer is the length of the diagonal from one corner of the rectangular screen to its opposite corner.

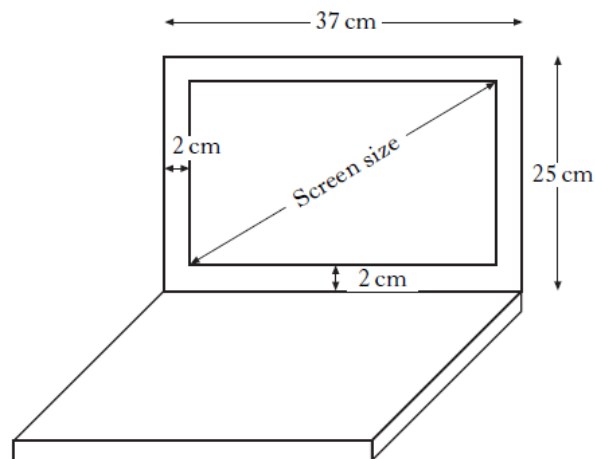

This laptop measures 37cm by 25cm as shown.

The frame around the screen has a width of 2cm.

Calculate the screen size of this laptop.

- 11) A flagpole snaps and falls over into the position shown.

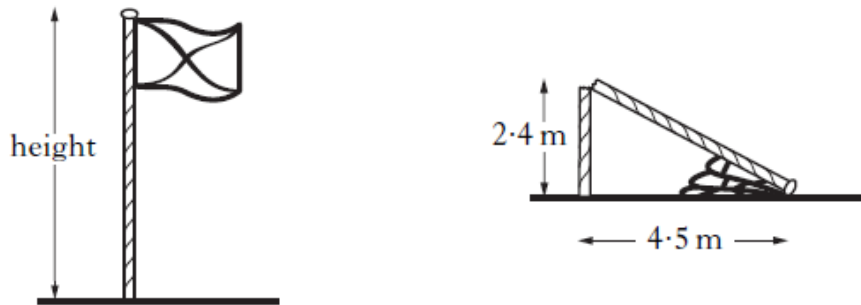

Calculate the height of the flagpole before it fell over.

- 12) The diagram shows the end view of a building.

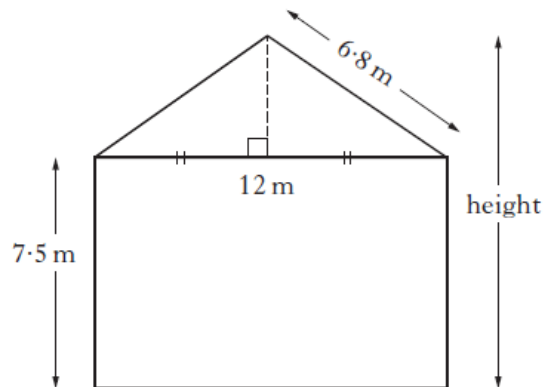

Calculate the total height of the building.

ANSWERS

1) $c^2 = 195^2 + 95^2$

$$c^2 = 38025 + 9025$$

$$c^2 = 47050$$

$$c = \sqrt{47050}$$

$$c = 216.9\text{cm} \quad \text{Phil's 2.2m piece of wood will be long enough.}$$

2) $WP^2 = 1 \cdot 1^2 + 0 \cdot 7^2$

$$WP^2 = 1 \cdot 21 + 0 \cdot 49$$

$$WP^2 = 1 \cdot 7$$

$$WP = \sqrt{1 \cdot 7}$$

$$WP = 1.3\text{m}$$

3) $c^2 = 20^2 + 20^2$

$$c^2 = 400 + 400$$

$$c^2 = 800$$

$$c = \sqrt{800}$$

$$c = 28.3 \quad \text{The longest chain is 28.3 inches.}$$

4) a) A(-2,0) B(2,-3)

b) $AB^2 = 3^2 + 4^2$

$$AB^2 = 9 + 16$$

$$AB^2 = 25$$

$$AB = \sqrt{25}$$

$$AB = 5$$

5) $PQ^2 = 7 \cdot 5^2 + 4^2$

$$PQ^2 = 56 \cdot 25 + 16$$

$$PQ^2 = 72 \cdot 25$$

$$PQ = \sqrt{72 \cdot 25}$$

$$PQ = 8.5\text{cm}$$

$$\begin{aligned}6) \quad c^2 &= 3 \cdot 8^2 + 0 \cdot 9^2 \\ c^2 &= 14 \cdot 44 + 0 \cdot 81 \\ c^2 &= 15 \cdot 25 \\ c &= \sqrt{15 \cdot 25} \\ c &= 3 \cdot 9\text{m}\end{aligned}$$

$$\begin{aligned}7) \quad c^2 &= 7^2 + 1^2 \\ c^2 &= 49 + 1 \\ c^2 &= 50 \\ c &= \sqrt{50} \\ c &= 7 \cdot 07\text{km} \quad \text{Total length of bypass is } 12 \cdot 07\text{km}.\end{aligned}$$

$$\begin{aligned}8) \quad 85^2 &= a^2 + 40^2 \\ 7225 &= a^2 + 1600 \\ a^2 &= 5625 \\ a &= \sqrt{5625} \\ a &= 75\text{cm} \quad \text{Gap} = 75 - 55 = 20\text{cm}\end{aligned}$$

$$\begin{aligned}9) \quad c^2 &= 70^2 + 100^2 \\ c^2 &= 4900 + 10000 \\ c^2 &= 14900 \\ c &= \sqrt{14900} \\ c &= 122 \cdot 1\text{cm}\end{aligned}$$

$$\begin{aligned}10) \quad c^2 &= 33^2 + 21^2 \\ c^2 &= 1089 + 441 \\ c^2 &= 1530 \\ c &= \sqrt{1530} \\ c &= 39 \cdot 1\text{cm}\end{aligned}$$

$$11) \quad c^2 = 2 \cdot 4^2 + 4 \cdot 5^2$$

$$c^2 = 5 \cdot 76 + 20 \cdot 25$$

$$c^2 = 26 \cdot 01$$

$$c = \sqrt{26 \cdot 01}$$

$$c = 5 \cdot 1\text{m}$$

$$\text{Height} = 5 \cdot 1 + 2 \cdot 4 = 7 \cdot 5\text{m}$$

$$12) \quad 6 \cdot 8^2 = a^2 + 6^2$$

$$46 \cdot 24 = a^2 + 36$$

$$a^2 = 10 \cdot 24$$

$$c = \sqrt{10 \cdot 24}$$

$$c = 3 \cdot 2\text{m}$$

$$\text{Height} = 3 \cdot 2 + 7 \cdot 5 = 10 \cdot 7\text{m}$$