

Practice Exam 1

1. Calculate the **compound interest** earned when £50 000 is invested for 4 years at 4.5% per annum.
Give your answer to the nearest penny.

4 marks

2. Irene works in the local chemist's shop.
One week she works 40 hours at her basic rate of pay and 3 hours overtime at double time.
Her gross pay for that week was £239.20.
Calculate Irene's basic hourly rate of pay.

3 marks

3. The results for a group of students who sat tests in mathematics and physics are shown below.

<i>Mathematics (%)</i>	10	18	26	32	49
<i>Physics (%)</i>	25	35	30	40	41

- (a) Calculate the standard deviation for the mathematics test.

4 marks

- (b) The standard deviation for physics was 6.8.

Make an appropriate comment on the distribution of marks in the two tests.

1 mark

These marks are shown on the scattergraph below.

The line of best fit has been drawn.

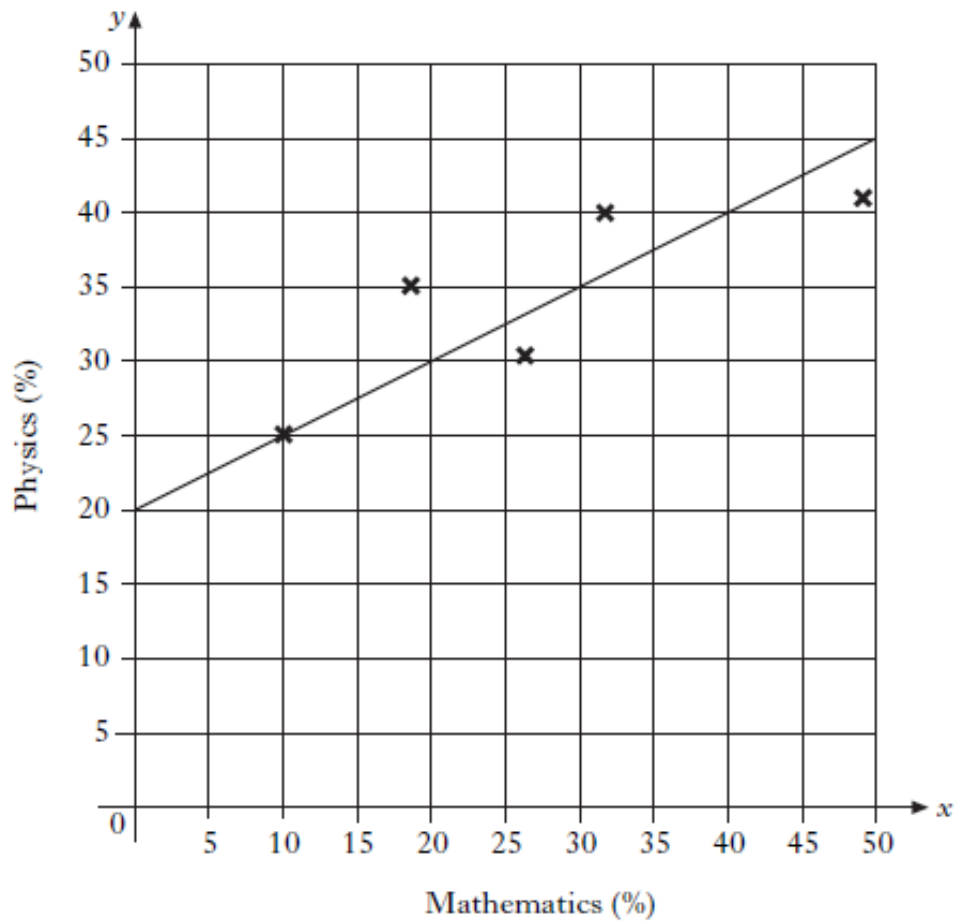

(c) Find the equation of the line of best fit.

3 marks

(d) Another pupil scored 76% in the mathematics test but was absent from the physics test.

Use your answer to part (c) to predict his physics mark.

1 mark

4. Luljeta Dumani sells carpets. Her gross annual salary for the last year was £15 425.

The table below shows the rates of tax applicable for last year.

Taxable Income	Rate
On the first £2230	10%
On the next £32 370	22%
On any income over £34 600	40%

Luljeta's total tax allowance is £5225.

Calculate her annual tax bill for last year.

4 marks

5. A company manufactures aluminium tubes.

The cross-section of one of the tubes is shown in the diagram below.

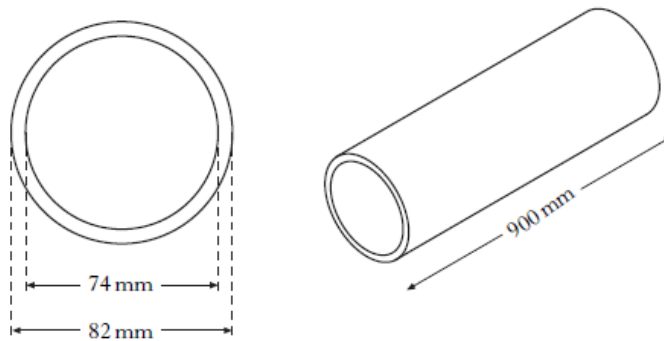

The inner diameter is 74 millimetres.

The outer diameter is 82 millimetres.

The tube is 900 millimetres long.

Calculate the volume of aluminium used to make the tube.

Give your answer correct to three significant figures.

5 marks

6. An off shore wind farm is on a bearing of 115° and at a distance of 90 kilometres from Eyemouth.
Using a scale of 1 centimetre to represent 10 kilometres, show the position of the wind farm on the diagram below.

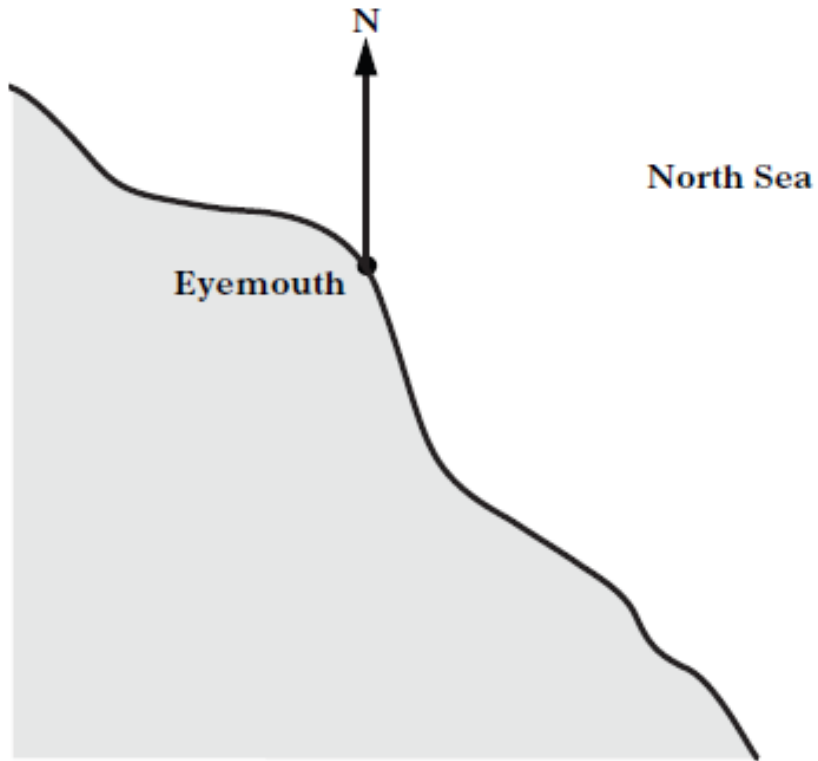

3 marks