

FOR OFFICIAL USE



National  
Qualifications  
2014

Mark

**X744/75/01**

**Lifeskills Mathematics  
Paper 1  
(Non-Calculator)**

FRIDAY, 9 MAY

1:00 PM – 1:50 PM



\* X 7 4 4 7 5 0 1 \*

Fill in these boxes and read what is printed below.

Full name of centre

Town

Forename(s)

Surname

Number of seat

Date of birth

Day

Month

Year

Scottish candidate number

**Total marks — 35**

Attempt ALL questions.

Write your answers in the spaces provided in this booklet. Additional space for answers is provided at the end of this booklet. If you use this space you must clearly identify question number you are attempting.

Use **blue** or **black** ink.

**You may NOT use a calculator.**

Full credit will be given only to solutions which contain appropriate working.

State the units for your answer where appropriate.

Before leaving the examination room you must give this booklet to the Invigilator; if you do not, you may lose all the marks for this paper.



\* X 7 4 4 7 5 0 1 0 1 \*

## FORMULAE LIST

Circumference of a circle:  $C = \pi d$

Area of a circle:  $A = \pi r^2$

Theorem of Pythagoras:

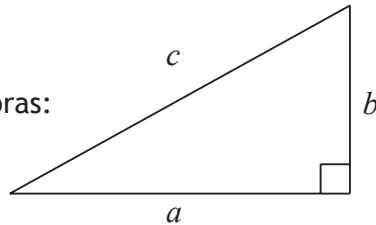

$$a^2 + b^2 = c^2$$

Volume of a cylinder:  $V = \pi r^2 h$

Volume of a prism:  $V = Ah$

Volume of a cone:  $V = \frac{1}{3} \pi r^2 h$

Volume of a sphere:  $V = \frac{4}{3} \pi r^3$

Standard deviation:  $s = \sqrt{\frac{\sum(x - \bar{x})^2}{n-1}} = \sqrt{\frac{\sum x^2 - (\sum x)^2/n}{n-1}}$ , where  $n$  is the sample size.

Gradient:

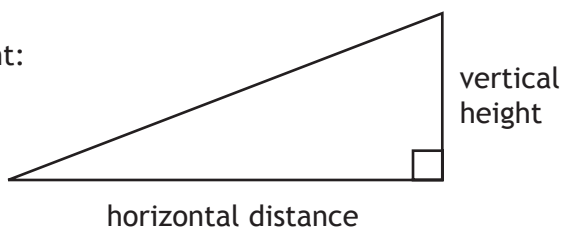

$$\text{gradient} = \frac{\text{vertical height}}{\text{horizontal distance}}$$



\* X 7 4 4 7 5 0 1 0 2 \*

## Attempt ALL questions

1. Mrs Abid took a survey in her mathematics class of how pupils travelled to school.

The results are shown in the table.

	Walk	Cycle	Bus
Boys	6	4	3
Girls	2	3	12

What is the probability that a pupil chosen at random is a girl who cycles to school?

Give your answer in its simplest form.

2

[Turn over



\* X 7 4 4 7 5 0 1 0 3 \*

**MARKS**

DO NOT  
WRITE IN  
THIS  
MARGIN

2. Frances is not feeling well.  
She takes her temperature using a thermometer.  
Her temperature is shown below.  
The temperature of a person in good health is  $36.8^{\circ}\text{C} \pm 0.4^{\circ}\text{C}$ .

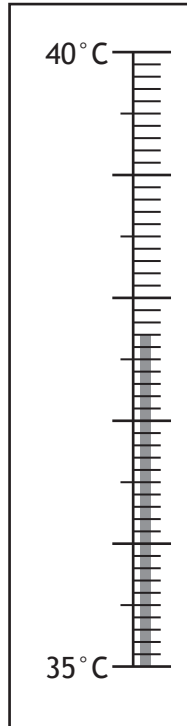

Is Frances in good health?

Give a reason for your answer.

**3**



MARKS

DO NOT  
WRITE IN  
THIS  
MARGIN

3. A new sail is being designed for a yacht as shown below.  
It consists of two right angled triangles.

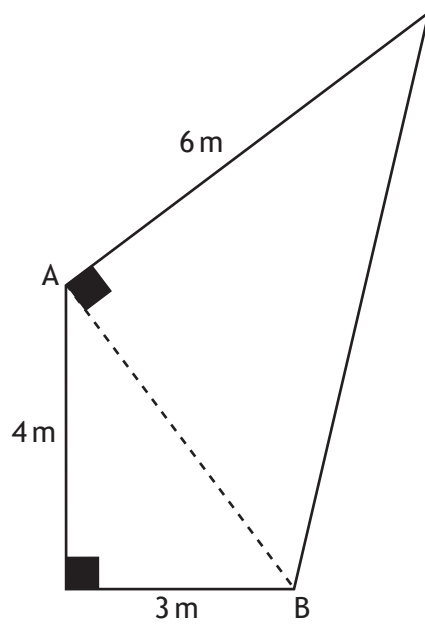

- (a) Calculate the length of AB.

1

- (b) Calculate the total area of the sail.

2

Total marks 3  
[Turn over



**MARKS**

DO NOT  
WRITE IN  
THIS  
MARGIN

4. Adam works for 40 hours per week as a tractor driver on a farm.  
His basic wage is £7·40 per hour.  
Each week he pays £28·43 Income Tax and £8·57 in National Insurance.

(a) Calculate his take home pay.

1



\* X 7 4 4 7 5 0 1 0 6 \*

4. (continued)

(b) Adam is going on holiday in 13 weeks.

The holiday costs £320 and Adam wants to take £200 spending money.

He makes a table to show his weekly income and outgoings.

He puts the balance into his holiday fund.

	Income	Outgoings
Take home pay		
Rent		£76
Bills		£41
Food		£45
Entertainment		£30
Transport		£23
<b>Holiday Fund</b>		

Will he have enough to cover the cost of the holiday and his spending money?

Justify your answer.

3

Total marks 4

[Turn over



MARKS

DO NOT  
WRITE IN  
THIS  
MARGIN

5. Reece is given a lift to school.  
She leaves the house at 8:30 am and arrives at school at 8:50 am.  
She uses an app on her phone to calculate her average speed for the journey.  
Her phone displays 6.8m/s.  
What distance did she travel?  
**Give your answer to 2 significant figures.**

4



\* X 7 4 4 7 5 0 1 0 8 \*



6. The Clarks employ Kitease to install a new kitchen for them.  
Kitease provide a team of workers to install the kitchen.  
The table shows the list of tasks and the time required for each.

Task	Detail	Preceding task	Time(hours)
A	Begin electrics	None	3
B	Build cupboards	None	5
C	Begin plumbing	None	2
D	Plaster walls	A,B,C	8
E	Fit wall cupboards	D	6
F	Fit floor cupboards	D	5
G	Fit worktops	F	3
H	Finish plumbing	G	3
I	Finish electrics	E,G	4

- (a) Complete the diagram below by writing these tasks and times in the boxes.

(An additional diagram, if required, can be found on *Page fifteen.*)

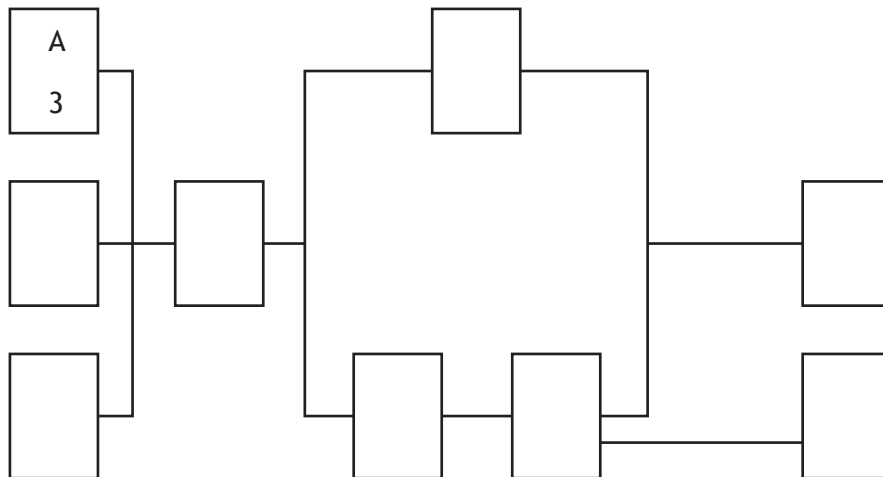

2

- (b) Kitease claim they can install this kitchen in 22 hours.

Is this a valid claim?

Give a reason for your answer.

2

Total marks 4

[Turn over



7. This back-to-back stem and leaf diagram represents the number of hours a class spends on social networking websites in a week.

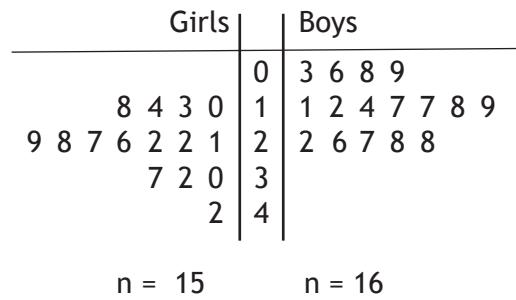

KEY

3 | 1 | represents 13 hours  
 2 | 5 | represents 25 hours

(a) A boxplot is drawn to represent one set of data.

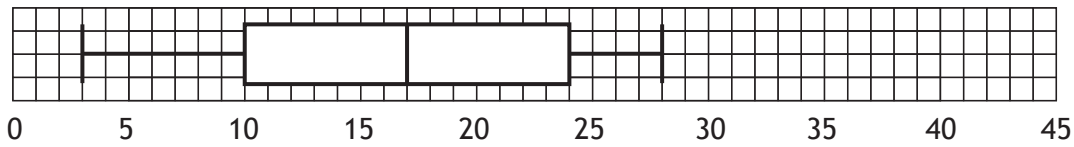

Which set of data does this represent?

Give a reason for your answer.

1

7. (continued)

(b) For the other set of data, state:

the median

the lower quartile

the upper quartile

2

(c) Construct a box plot for the second set of data.

(An additional diagram, if required, can be found on *Page fifteen.*)

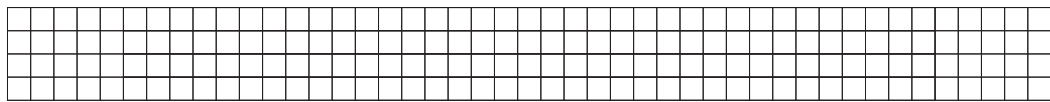

2

**Total marks** 5

[Turn over



\* X 7 4 4 7 5 0 1 1 1 \*

**MARKS**

DO NOT  
WRITE IN  
THIS  
MARGIN

8. Elaine goes on a 5 day long business trip to Oslo in Norway. She changes £750 to Norwegian kroner for the trip.

Rates of exchange	
Pounds Sterling (£)	Other Currencies
1	NOK 8.00 (Norwegian kroner)
1	€1.20 (euros)

- (a) How many Norwegian kroner will Elaine receive?

1



## 8. (continued)

- (b) Elaine spends NOK 520 each day she is in Norway.

Her company extends her trip by sending her to Munich in Germany for a further 3 days.

If she changes all her remaining kroner to euros, how many euros will she receive?

She spends €135 each day she is in Munich.

How much money does she have left at the end of her trip?

**Give your answer in pounds sterling.**

5

Total marks 6

[Turn over for Question 9 on *Page Fourteen*]



\* X 7 4 4 7 5 0 1 1 3 \*

MARKS

DO NOT  
WRITE IN  
THIS  
MARGIN

9. Robbie has a tub for his crayons.  
It is in the shape of a pencil as shown below.  
It consists of a cylinder with a cone on top.

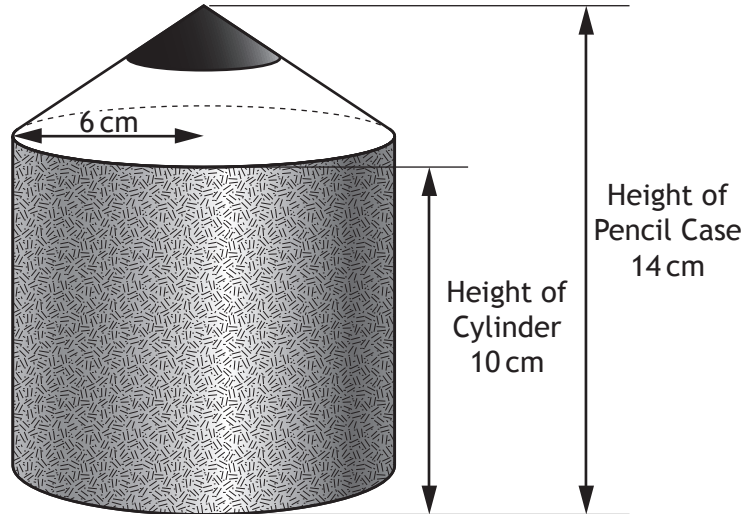

Show that the volume of Robbie's tub is  $408 \pi \text{ cm}^3$ .

4

[END OF QUESTION PAPER]



\* X 7 4 4 7 5 0 1 1 4 \*

ADDITIONAL SPACE FOR ANSWERS

MARKS  
DO NOT WRITE IN THIS MARGIN

Additional diagram for Question 6 (a)

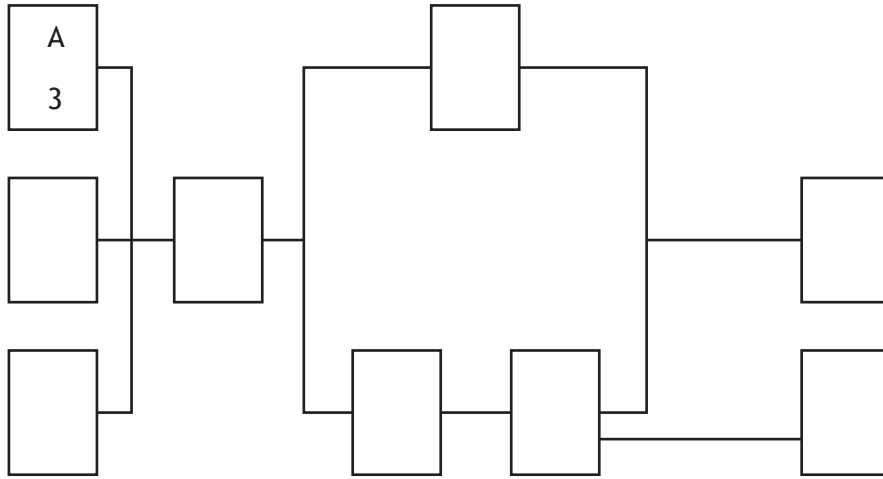

Additional diagram for Question 7 (c)

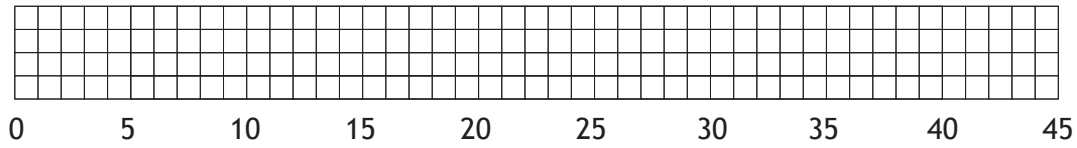

ADDITIONAL SPACE FOR ANSWERS

MARKS

DO NOT  
WRITE IN  
THIS  
MARGIN



\* X 7 4 4 7 5 0 1 1 6 \*



FOR OFFICIAL USE



National  
Qualifications  
2014

Mark

**X744/75/02**

**Lifeskills Mathematics  
Paper 2**

FRIDAY, 9 MAY

2:10 PM - 3:50 PM



\* X 7 4 4 7 5 0 2 \*

Fill in these boxes and read what is printed below.

Full name of centre

Town

Forename(s)

Surname

Number of seat

Date of birth

Day

Month

Year

Scottish candidate number

**Total marks — 55**

**Attempt ALL questions.**

Write your answers clearly in the spaces provided in this booklet. Additional space for answers is provided at the end of this booklet. If you use this space you must clearly identify the question number you are attempting.

Use **blue** or **black** ink.

**You may use a calculator.**

Full credit will be given only to solutions which contain appropriate working.

State the units for your answer where appropriate.

Before leaving the examination room you must give this book to the Invigilator; if you do not, you may lose all the marks for this paper.



\* X 7 4 4 7 5 0 2 0 1 \*

## FORMULAE LIST

Circumference of a circle:  $C = \pi d$

Area of a circle:  $A = \pi r^2$

Theorem of Pythagoras:

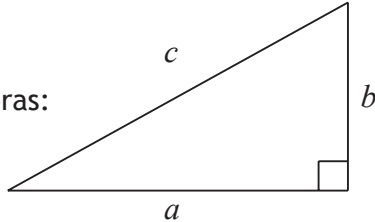

$$a^2 + b^2 = c^2$$

Volume of a cylinder:  $V = \pi r^2 h$

Volume of a prism:  $V = Ah$

Volume of a cone:  $V = \frac{1}{3} \pi r^2 h$

Volume of a sphere:  $V = \frac{4}{3} \pi r^3$

Standard deviation:  $s = \sqrt{\frac{\sum(x - \bar{x})^2}{n-1}} = \sqrt{\frac{\sum x^2 - (\sum x)^2/n}{n-1}}$ , where  $n$  is the sample size.

Gradient:

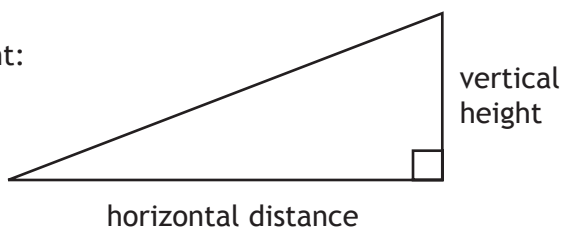

$$\text{gradient} = \frac{\text{vertical height}}{\text{horizontal distance}}$$



\* X 7 4 4 7 5 0 2 0 2 \*

Attempt ALL questions

MARKS

DO NOT  
WRITE IN  
THIS  
MARGIN

1. Over an eight month period, Goran records how much he spends on his pay-as-you-go mobile phone.

£32, £23, £43, £40, £27, £35, £15, £25.



Calculate the mean and standard deviation for this data.

4

[Turn over







\* X 7 4 4 7 5 0 2 0 3 \*

2. The Yellow Jersey Cycle Shop is a retail store that sells items for outdoor activities.

Alan has a 10% discount card for this store.

He receives a flyer showing the store's monthly deals.

He wants to buy all of the following items.

	<p><b>Mountain Bike</b> Recommended Retail Price £310 Price with discount card £279</p>
	<p><b>Helmet</b> Recommended Retail Price £20 Price with discount card £18</p>
	<p><b>Waterproof Jacket</b> Recommended Retail Price £50 Price with discount card £45</p>
	<p><b>Cycling Shorts</b> Recommended Retail Price £10 Price with discount card £9</p>

**Monthly Deal 1**

Extra 15% off discounted price when you spend over £75 in store.

Terms & Conditions.

1. Can be used in conjunction with 10% discount card.
2. Not to be used with any other offer or monthly deal.
3. Valid until end of May.

**Monthly Deal 2**

Extra 65% off discounted price of bike accessories and clothing when you purchase a bike in store.

Terms & Conditions.

1. Can be used in conjunction with 10% discount card.
2. Not to be used with any other offer or monthly deal.
3. Valid until end of May.



\* X 7 4 4 7 5 0 2 0 4 \*

Question 2 (continued)

- (a) Which Monthly Deal is better value for Alan?  
Justify your answer.

3

- (b) After he has bought the items Alan notices the following on his receipt.

**The Yellow Jersey Cycle Shop  
Price Guarantee**

If any product can be found cheaper (including on special offer) then we will refund the difference plus 10% of the difference.

Alan finds exactly the same items at The Red Polka Dot Cycle Shop who are having a clearance sale.

They are giving  $\frac{1}{3}$  off the Recommended Retail Price of all the items that Alan has just bought.

How much refund is he entitled to if he uses the **Price Guarantee** from The Yellow Jersey Cycle Shop?

3

Total marks 6  
[Turn over



3. A number of oil rigs operate in the North Sea.

The map below shows part of the North Sea with the ports of Aberdeen and Ringkobing marked.

(An additional map, if required, can be found on *Page fourteen*.)

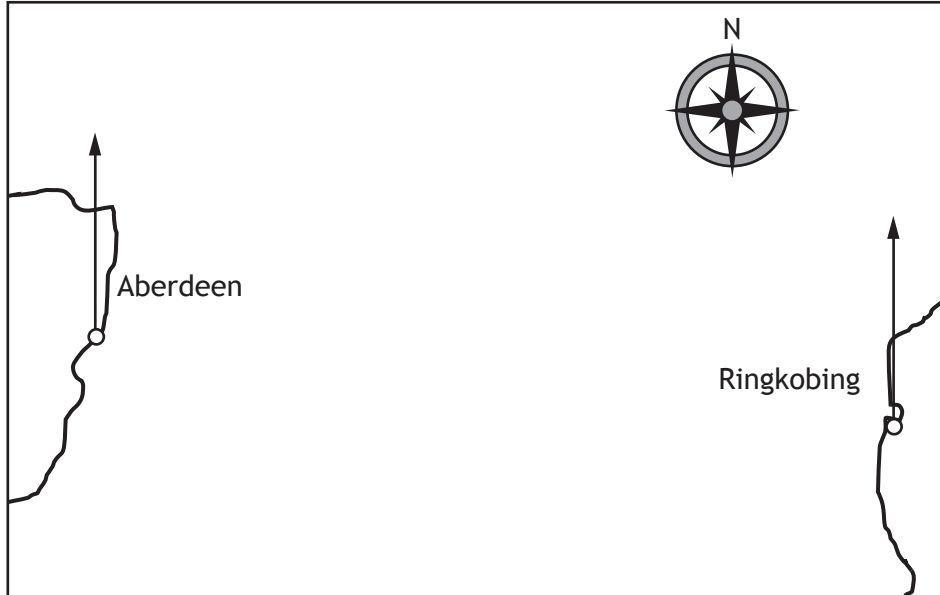

Scale 1 centimetre represents 50 kilometres

(a) Harkins oil rig is 380 km from Aberdeen on a bearing of 065°.

Show the position of the Harkins oil rig on the map above.

2

(b) A fishing vessel issues an SOS call which is received by both ports.

The bearing of the fishing vessel from each port is shown in the table below.

Bearing from	Three figure bearing
Aberdeen	125°
Ringkobing	250°

(i) Mark the position of the fishing vessel on the map.

3

(ii) Find the distance and bearing of the fishing vessel from the oil rig.

2

Total marks 7



**MARKS**

DO NOT  
WRITE IN  
THIS  
MARGIN

4. Saraish bought her house in May 2009 for £130 000.

In the first two years the value of the house increased by 5% per annum.

For the next three years the value of the house decreased by 2% per annum.

(a) What is the value of the house in May 2014?

**Give your answer to the nearest thousand pounds.**

**5**

(b) House prices have risen on average by 4.5% over this five year period.

Has the value of Saraish's house risen in line with this average?

**Give a reason for your answer.**

**2**

**Total marks 7**

**[Turn over**



\* X 7 4 4 7 5 0 2 0 7 \*

5. A landscape gardener is designing a garden.  
 The rectangular garden has dimensions 15 metres by 10 metres.  
 He plans to build a triangular flower bed.  
 To separate the flower bed from the lawn, he uses a low fence.  
 The fence is made of 5 sections, each 2.8 metres long.  
 A patio in the shape of a quarter circle with a radius of 5 metres is to be created in the corner.  
 The rest of the garden is to be laid as turf.  
 A sketch of the garden is shown below.

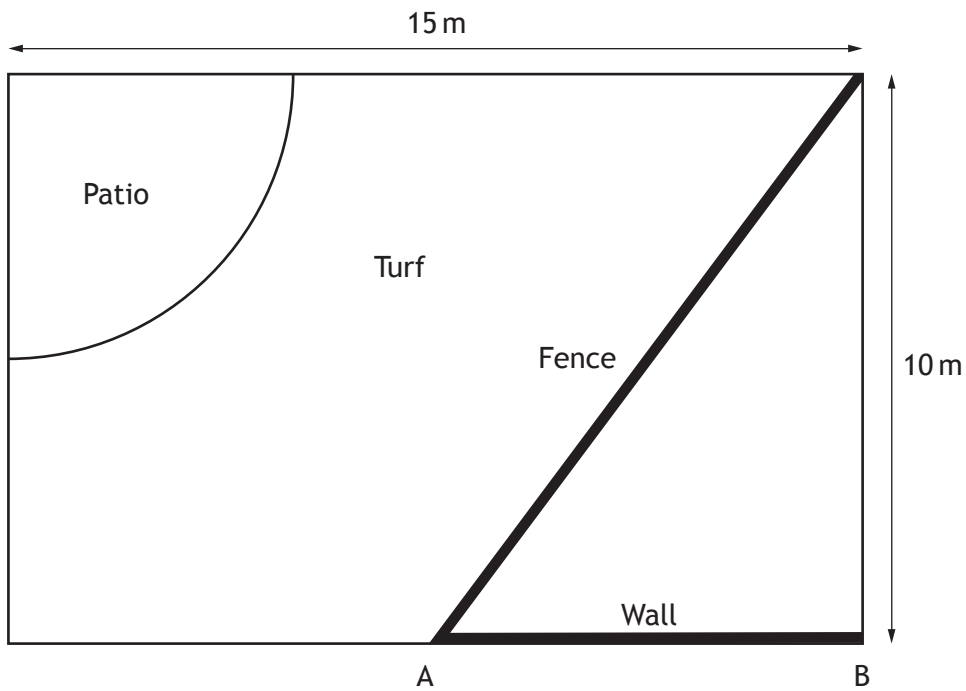

- (a) Calculate the length of the wall, AB.

3







6. The table shows the qualifying times at the Malaysian 2013 Grand Prix.  
The qualifying times are for 1 lap of the track.  
The track is 5.543 kilometres long.  
There are 56 laps in this Grand Prix.

	Driver	Team	Qualifying Time (min: sec)
1	Sebastian Vettel	Red Bull	01:49.7
2	Felipe Massa	Ferrari	01:50.6
3	Fernando Alonso	Ferrari	01:50.7
4	Lewis Hamilton	Mercedes	01:51.7
5	Mark Webber	Red Bull	01:52.2
6	Nico Rosberg	Mercedes	01:52.5

- (a) Vettel's time was 1 minute 49.7 seconds.  
By how much time did Vettel beat Massa?

1

- (b) What was Lewis Hamilton's average speed in his qualifying lap?  
Round your answer to the nearest km/h.

5



**MARKS**

DO NOT  
WRITE IN  
THIS  
MARGIN

6. (continued)

- (c) Nico Rosberg's average lap time for the Grand Prix was 1 minute 54.8 seconds.

How long did it take him to complete the Grand Prix?

Give your answer in hours, minutes and seconds.

4

Total marks 10

[Turn over



\* X 7 4 4 7 5 0 2 1 1 \*

7. Cameron wants to resurface his drive.  
He has a choice of 3 surfaces.

**SURFACE TYPE 1: TARMAC**

A tarmac drive should last for 30 years.

Tarmac costs £2 per square foot to lay.

(1 square metre = 10.76 square feet)

**SURFACE TYPE 2: GRAVEL CHIPS**

A gravel drive should last for 10 years.

Gravel needs to be laid to a depth of 5 cm.

Each 50 kg bag will cover 1 square metre to a depth of 5 cm.

Each 50 kg bag costs £8.29

Each 850 kg bag costs £125.99

The gravel needs a weedproof membrane to be laid underneath.

Membrane to cover the drive costs £14.31.

**SURFACE TYPE 3: CONCRETE SLABS**

A concrete slab drive should last for 25 years.

Concrete slabs:

40 cm by 40 cm ----- £2.12 each

Slabs can be cut to size

Slabs require 4 cm depth of hardcore to be laid underneath.

1 cubic metre = 2 tonnes hardcore.

Hardcore costs £18 per tonne bag.

2 bags of mortar at £35.99 per bag.

Cameron makes a sketch of his drive to help him to calculate the cost of each type of surface.

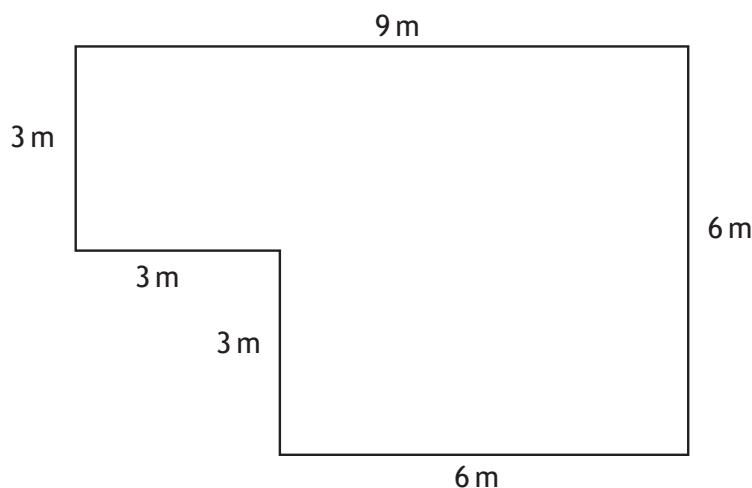

**MARKS**

DO NOT  
WRITE IN  
THIS  
MARGIN

7. (continued)

(a) Calculate the minimum total cost for each surface type.

9

(b) Which is the most cost effective?

3

Total marks 12

[END OF QUESTION PAPER]



\* X 7 4 4 7 5 0 2 1 3 \*

ADDITIONAL SPACE FOR ANSWERS

DO NOT  
WRITE IN  
THIS  
MARGIN

Additional map for Question 3

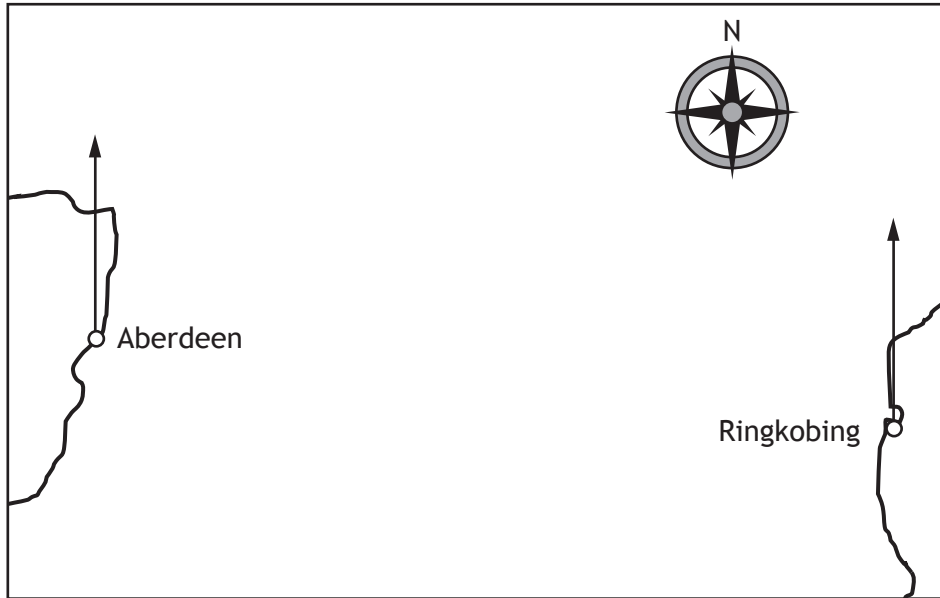

\* X 7 4 4 7 5 0 2 1 4 \*

ADDITIONAL SPACE FOR ANSWERS

DO NOT  
WRITE IN  
THIS  
MARGIN



\* X 7 4 4 7 5 0 2 1 5 \*



## ACKNOWLEDGEMENTS

Question 1—57367663 cobalt88/Shutterstock.com

Question 2—19717114 hamurishi/Shutterstock.com; 72108172 Photoseeker/Shutterstock.com;  
110069363 Aaron Amat/Shutterstock.com; 57154600 nito/Shutterstock.com

